

# MOUNTING KITS

FOR Z6 LOAD CELLS 10 kg ... 500 kg



- The key to high-precision performance in industrial weighing
- Rated capacity 10 kg ... 500 kg

The mounting kits RGP 10A2/10B2, RGP 20A2/20B2 and RGP 60A2 are designed especially for Z6 load cells. The mounting kits facilitate assembling of scales, mounting of load cells and force transmission to the load cell.

The kits also eliminate disturbances found in conventional load cell assemblies to the measuring results, such as measurement changes due to loading or thermal expansion, lateral forces caused by process equipment or vibration.



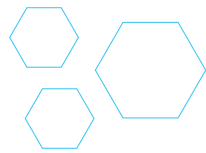

## RGP 10A2/10B2

**PENDULUM SUPPORT mounting kit**  
for Z6 10 kg ... 200 kg / 500 kg

This mounting kit ensures a perfectly aligned non-friction transmission of the force to the load cell. The load is free to move all the way to the lateral limiter (measurement P) without friction, thanks to the rolling between two tempered surfaces - flat and spherical. With properly dimensioned spherical surfaces, the construction is self-centering and the force coming from the load is carried to the load cells faultlessly, irrespective of the bending and thermal expansion of the structures.

The mounting kit is suited for use in all weighing applications with three or more load cells. The kit is equipped with an adjustable overload stop screw to protect the load cell.

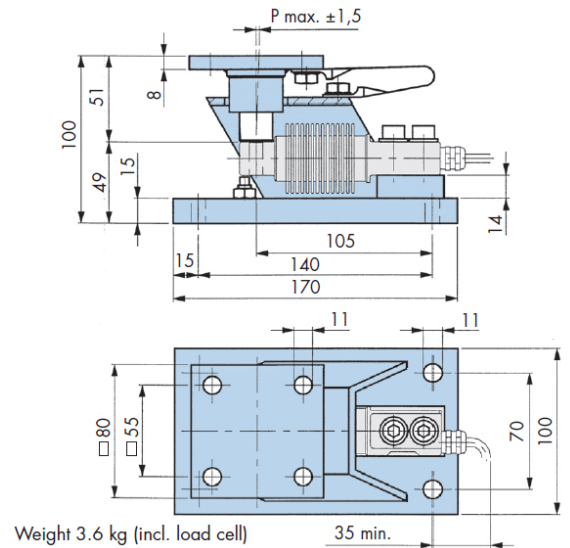

Weight 3.6 kg (incl. load cell)  
Centering force  $F_k = 7.7 \text{ \%/mm}$  (measurement P) of the force acting on the load cell.

## RGP 20A2/20B2

**TENSION BAR mounting kit**  
for Z6 load cell 10 kg ... 200 kg / 500 kg

This mounting kit is designed for situations, where the transmission to the load cell takes place by traction. The kit is especially well suited for suspended loads, for example, in weighing hoppers and for the measurement of force.

The RGP 20A2/20B2 kit includes and adjustable overload stop to protected the load cell.

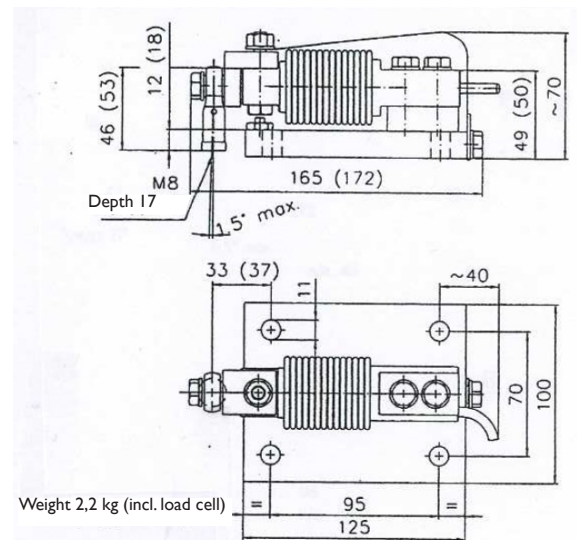

## RGP 60A2

**ELASTOMER mounting kit**  
for Z6 load cell 10 kg ... 200 kg / 500 kg

The rubber parts absorb shock action and vibration, and the self-centering construction offsets any bending of the structures under the load, minor mounting errors and thermal expansion. This kit is suited for scales with three load cells.

Typical weighing applications include silos, tanks and mixers and especially facilities with strong disturbance caused by process equipment.

The RGP 60A2 kit includes an adjustable overload stop crew to protect the load cell.

