

55-20 weigh module



product description

Flintec load cell supports are designed to prevent unwanted forces from affecting load cell performance.

The 55-20 is a self-aligning weigh module, with excellent load introduction. The module is specially designed for Flintec's RC3 rocker column load cell for use in hopper and tank weighing applications. The module incorporates an integrated bumper-stop eliminating the need of using check links thereby offering highest possible precision. The weigh module is shipped completely pre-assembled; ready for installation by welding or bolting.

applications

Silo and tank weighing systems.

available version

	7.5t - 22.5t	30t / 40t	50t / 100t	150t	300t
Bolted version	✓	✓	✓	-	-
Casted version	-	-	✓	✓	✓

key features

Wide range of capacities from 7.5t through to 300t

Mild steel, zinc plated (bolted v.)
Cast mild steel, painted (casted v.)

Very easy to install

Especially designed for hopper and tank weighing

Integrated bumper-stop for the highest precision

Integrated lift-off protection

Load cell replacement requires minimum lifting height

Rocking action of load cells allows for temperature expansion

RoHS
compliant



bolted version dimensions (mm)

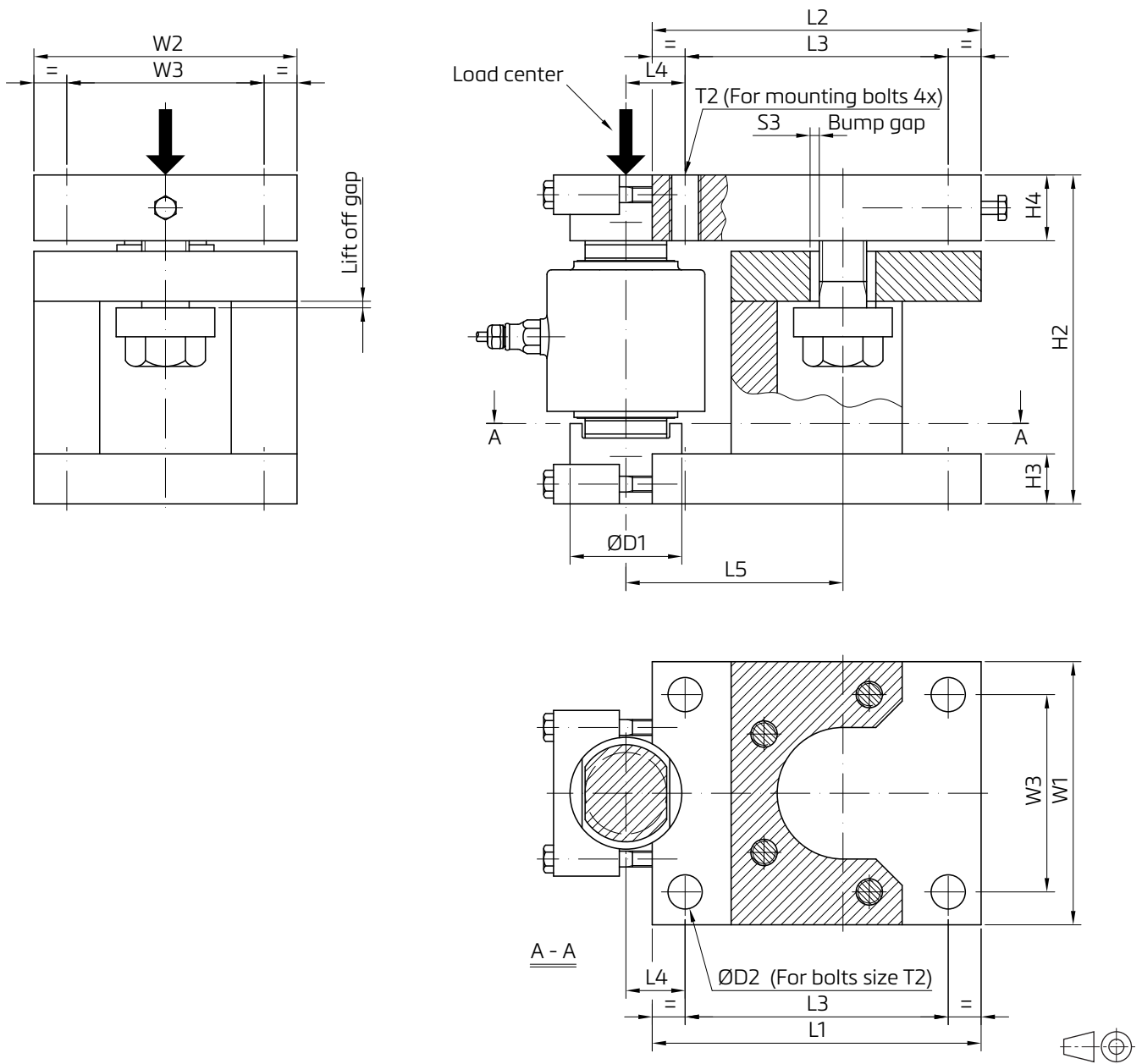

Load cell type	D1	D2	H2	H3	H4	L1	L2	L3	L4	L5	W1	W2	W3	S3	T2	Max lift off force (kN) *	Max side force (kN)*	Weigh excl load cell (kg)
RC3-7.5/15/22.5t	50	17.5	130	20	30	166	160	130	25	100	130	130	100	5	M16	100	50	15
RC3-30/40t	60	22	200	29	40	210	210	170	30	125	150	150	110	6	M20	180	90	32
RC3-50/100t	85	26	250	38	50	250	250	200	45	165	200	200	150	7	M24	300	150	65

Note:

- In tank/silo applications with 3 respectively 4 weigh modules can be assumed that minimum 2 modules will equally share actual side force (wind) on the tank/silo.
 - Actual lift off force shall, for worst case, be assumed being taken by one module.
- For seismic events, the minimum break loads are increased to 200% of lift-off forces and 250% of side forces.

casted version dimensions (mm)

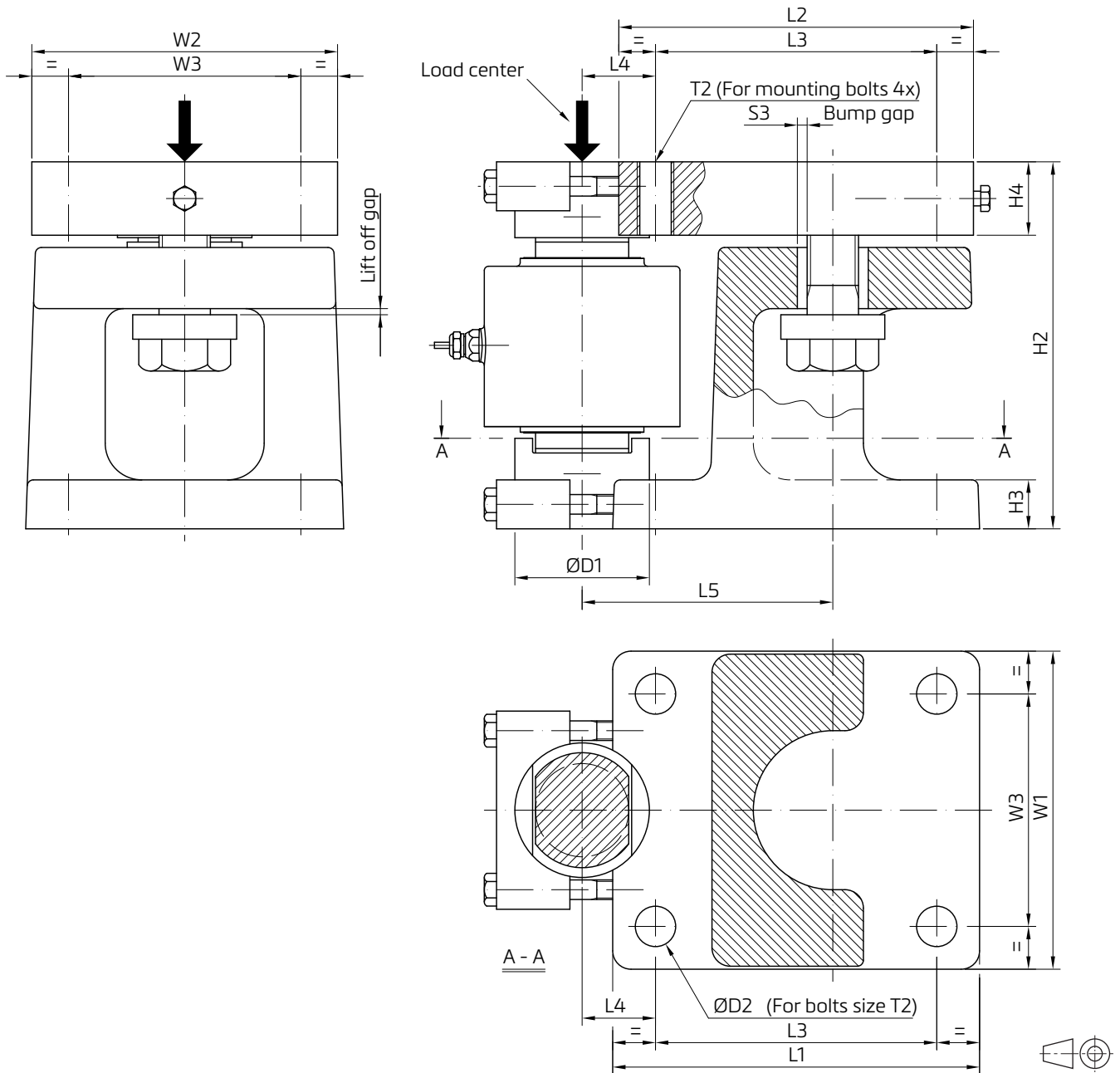

Load cell type	D1	D2	H2	H3	H4	L1	L2	L3	L4	L5	W1	W2	W3	S3	T2	Max lift off force (kN) *	Max side force (kN)*	Weigh excl load cell (kg)
RC3-50t/100t	85	26	250	34	50	260	250	200	45	165	210	200	150	7	M24	300	150	65
RC3-150t	110	33	300	40	60	300	290	230	60	205	260	250	190	8	M30	400	200	113
RC3-300t	135	39	400	60	70	370	350	280	65	235	320	300	230	10	M36	600	300	225

Note:

- In tank/silo applications with 3 respectively 4 weigh modules can be assumed that minimum 2 modules will equally share actual side force (wind) on the tank/silo.
 - Actual lift off force shall, for worst case, be assumed being taken by one module.
- For seismic events, the minimum break loads are increased to 200% of lift-off forces and 250% of side forces.

upside-down installation

The weigh module can be installed upside down to get through holes $\varnothing D2$ on top. This is shown below.

Bolted version

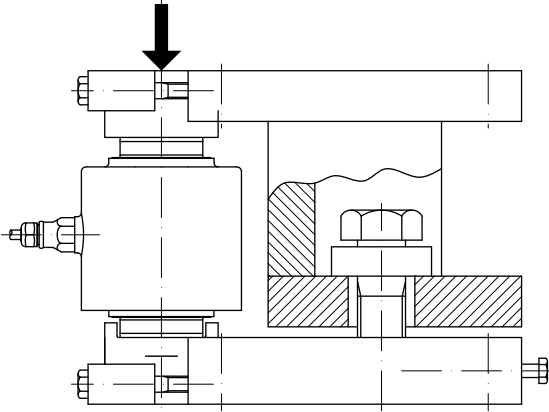

Casted version

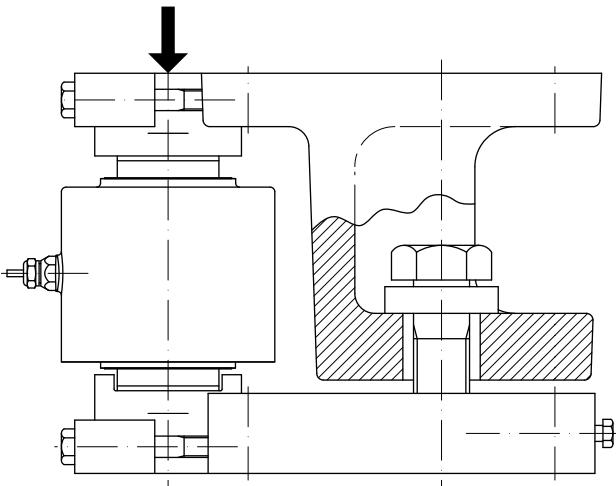

general notes

The module can preferably be welded to tank foot and foundation plate. This eliminates problems of getting holes on top and bottom lined up. Or for example bolted on top and welded on bottom.

attention

- Mounting bolts are not included in delivery.
- Silo foot and foundation plate to be horizontal:
 - within 0.4/100 for legal for trade applications,
 - within 0.8/100 for general applications.

Dimensions and specifications are subject to change without notice.