

SBK

SBK SERIES IP68 STAINLESS STEEL SHEAR BEAM LOAD CELLS, from 300kg to 2000kg



Stainless steel shear beam load cells suitable for building, for example, CE-M approved scales with 4 load cells or for weighing tanks and hoppers with the relevant accessories.

CAPACITIES (kg): 300, 500, 1000, 2000.

OIML R60. C3 precision class.

Stainless steel. IP68 protection.

Output Resistance **350 Ohm**.

Working in cooperation with:

TAMTRON AS

VESTVOLLVEIEN 30B - 2019 - SKEDSMOKORSET - NORWAY

Tel. +47 64 83 67 50

post@tamtron.no www.tamtron.no

The best solution
for advanced industrial
applications

MAIN FEATURES

- C3 PRECISION CLASS
- STAINLESS STEEL CONSTRUCTION
- IP68 PROTECTION
- MAX. CAPACITIES FROM 300 TO 2000 kg
- SHIELDED CONNECTION CABLE
- OIML CERTIFICATE AVAILABLE UPON REQUEST
- TEST CERTIFICATE AVAILABLE UPON REQUEST

TECHNICAL FEATURES

- Minimum load cell verification interval: $V_{min} = E_{Max} / 10.000$
- Maximum number of verification intervals: $nLC = 3000$
- Combined error: 0,017% of Full Scale Output (F.S.)
- Full Scale Output: 2mV/V +/- 0.1%
- Temperature effect on zero: 0,0014% /°C
- Temperature effect on full scale output: 0,0014% /°C
- Compensated Temperature Range: -10°C/+40°C
- Operating Temperature Range: -20°C/+60°C
- Creep error after 30 minutes: 0,024% F.S.
- Maximum tolerated excitation voltage: 15 VDC
- Input Resistance: 385 ± 20 Ohm
- Output Resistance: 350 ± 5 Ohm
- Insulation Resistance: >5000 MOhm
- Safe Overload: 150% F.S.
- Ultimate Overload: 200% F.S.
- 6-wire shielded cable, 5m long, 5 mm diameter

ATEX VERSION

- The CCATEX certificate makes the load cell suitable for use in hazardous areas with protection methods according to:
ATEX II 1G Ex ia IIC T6 (Ta -20÷+40°C) TX (Ta -20÷+65°C) Ga
ATEX II 1D Ex ta IIIC TX°C (Ta -20÷+40°C) TX°C (Ta -20÷+65°C) Da IP65.
The certificate includes the manual and the ATEX CE conformity declaration (available in EN, DE, FR, and IT).
- **IMPORTANT:** the certificate refers to the single load cell. For systems with more load cells, it is necessary to order one certificate for each load cell.

MAIN CERTIFICATIONS

- OIML R60
- Australian legal for trade certificate of approval (NMI S841)

DETAIL 1

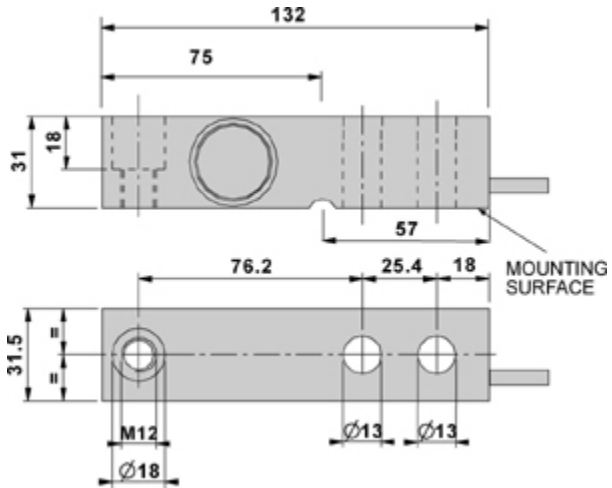

Dimensions (mm)

Wiring Code	
Colour	Function
--	SHIELD
YELLOW	OUTPUT +
GREY	SENSE +
BROWN	INPUT +
WHITE	OUTPUT -
GREEN	INPUT -
PINK	SENSE -

VERSIONS

Available versions

Codice	Max (kg)
SBK300 	300
SBK500 	500
SBK1000 	1000
SBK2000 	2000



“YOUR WORLDWIDE PARTNER FOR WEIGHING,”

DINI ARGEO
FRANCE sarl
France

DINI ARGEO
GMBH
Germany

DINI ARGEO
UK Ltd
United Kingdom

DINI ARGEO WEIGHING
INSTRUMENTS Ltd
China

DINI ARGEO
OCEANIA
Australia



COMPANY HEADQUARTERS

Via Della Fisica, 20
41042 Spezzano di Fiorano - Modena - Italy
Tel. +39.0536 843418

TAMTRON AS

VESTVOLLVEIEN 30B - 2019 - SKEDSMOKORSET - NORWAY

Tel. +47 64 83 67 50

post@tamtron.no www.tamtron.no

SALES AND TECHNICAL ASSISTANCE SERVICE