

SBX1KL10000

SBX-1KL SERIES SHEAR BEAM LOAD CELLS, 10000kg



Stainless steel approved shear beam load cells, with low-power 1000 Ohm output resistance for mobile battery applications. Suitable for creating CE-M approved scales with 4 load cells, or for weighing tanks and hoppers, with the aid of its accessories.

CAPACITIES (kg): 10000.

OIML R60. C3 precision class.

Stainless steel. IP68 protection.

Output Resistance **1000 Ohm**.

Working in cooperation with:

TAMTRON AS

VESTVOLLVEIEN 30B - 2019 - SKEDSMOKORSET - NORWAY
Tel. +47 64 83 67 50
post@tamtron.no www.tamtron.no

The best solution
for advanced industrial
applications

MAIN FEATURES

- C3 PRECISION CLASS
- STAINLESS STEEL CONSTRUCTION WITH LASER WELDING
- IP68 PROTECTION, IP69K UPON REQUEST
- CAPACITIES 10000 kg
- SHIELDED CONNECTION CABLE
- TEST CERTIFICATE PROVIDED AS STANDARD

TECHNICAL FEATURES

- Minimum load cell verification interval $V_{min} = E_{Max} / 10.000$
- Maximum number of verification intervals $n_{LC} = 3000$
- Combined error 0,017% of Full Scale Output (F.S.)
- Full Scale Output 2mV/V +/- 0.5%
- Temperature effect on zero 0,002% / °C
- Temperature effect on full scale output 0,002% / °C
- Compensated Temperature Range -10°C/+50°C
- Operating Temperature Range -20°C/+60°C
- Creep error after 30 minutes 0,02% F.S.
- Maximum tolerated excitation voltage 15 VDC
- Input Resistance 1100 ± 20 Ohm.
- Output Resistance 1000 ± 20 Ohm.
- Insulation Resistance >5000 MOhm
- Safe Overload 120% F.S.
- Ultimate Overload 300% F.S.
- 6-wire shielded cable, 5m long, 5 mm diameter

ATEX VERSION

- The CCATEX certificate makes the load cell suitable for use in hazardous areas with protection methods according to:
ATEX II 1G Ex ia IIC T6 (Ta -20÷+40°C) TX (Ta -20÷+65°C) Ga
ATEX II 1D Ex ta IIIC TX°C (Ta -20÷+40°C) TX°C (Ta -20÷+65°C) Da IP65.
The certificate includes the manual and the ATEX CE conformity declaration (available in EN, DE, FR, and IT).
- **IMPORTANT:** the certificate refers to the single load cell. For systems with more load cells, it is necessary to order one certificate for each load cell.

DIMENSIONS - DECODING STANDARD CABLE

- NOTE: dimensions in mm

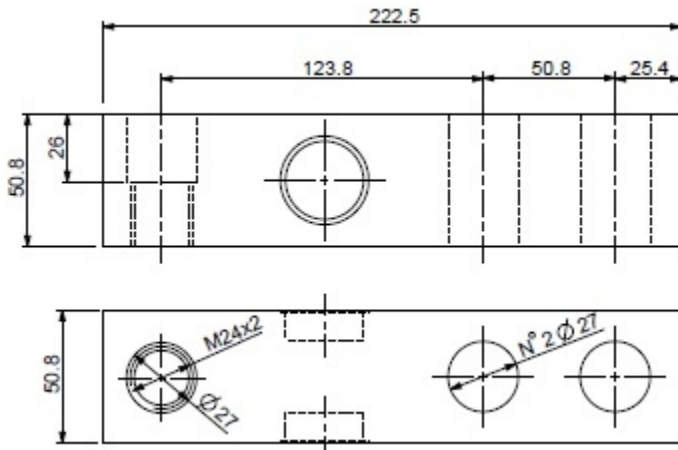

- Decoding of the standard cable colours

Colour	Function
--	SHIELD
YELLOW	OUTPUT +
GREY	SENSE +
BROWN	INPUT +
WHITE	OUTPUT -
GREEN	INPUT -
PINK	SENSE -

MAIN CERTIFICATIONS

- OIML R60
- Australian legal for trade certificate of approval (NMI S841)

VERSIONS

Available versions

Codice	Max (kg)
SBX10000-1KL 	10000



“YOUR WORLDWIDE PARTNER FOR WEIGHING,”

DINI ARGEO
FRANCE sarl
France

DINI ARGEO
GMBH
Germany

DINI ARGEO
UK Ltd
United Kingdom

DINI ARGEO WEIGHING
INSTRUMENTS Ltd
China

DINI ARGEO
OCEANIA
Australia



COMPANY HEADQUARTERS

Via Della Fisica, 20
41042 Spezzano di Fiorano - Modena - Italy
Tel. +39.0536 843418

TAMTRON AS

VESTVOLLVEIEN 30B - 2019 - SKEDSMOKORSET - NORWAY

Tel. +47 64 83 67 50

post@tamtron.no www.tamtron.no

SALES AND TECHNICAL ASSISTANCE SERVICE